

ESRP Storage Program
EMC CLARiiON CX3-20c (600 User) iSCSI with LCR
Storage Solution for Microsoft Exchange Server 2007

Tested with: ESRP – Storage Version 2.0
Tested Date: 12/04/07

EMC Corporation
Corporate Headquarters
Hopkinton, MA 01748-9103
1-508-435-1000
www.EMC.com

EMC believes the information in this publication is accurate as of its publication date. The information is subject to change without notice.

THE INFORMATION IN THIS PUBLICATION IS PROVIDED "AS IS." EMC CORPORATION MAKES NO REPRESENTATIONS OR WARRANTIES OF ANY KIND WITH RESPECT TO THE INFORMATION IN THIS PUBLICATION, AND SPECIFICALLY DISCLAIMS IMPLIED WARRANTIES OF MERCHANTABILITY OR FITNESS FOR A PARTICULAR PURPOSE.

Use, copying, and distribution of any EMC software described in this publication requires an applicable software license.

EMC², EMC, EMC ControlCenter, AlphaStor, ApplicationXtender, Avamar, Captiva, Catalog Solution, Celerra, Centera, CentraStar, CLARAlert, CLARiON, ClientPak, CodeLink, Connectrix, Co-StandbyServer, Dantz, Direct Matrix Architecture, DiskXtender, DiskXtender 2000, Documentum, EmailXaminer, EmailXtender, EmailXtract, eRoom, FLARE, HighRoad, InputAccel, Invista, Max Retriever, Navisphere, NetWorker, nLayers, OpenScale, Powerlink, PowerPath, Rainfinity, RepliStor, ResourcePak, Retrospect, Smarts, SnapShotServer, SnapView/IP, SRDF, Symmetrix, TimeFinder, VisualSAN, VSAM-Assist, WebXtender, where information lives, Xtender, and Xtender Solutions are registered trademarks and EMC Developers Program, EMC OnCourse, EMC Proven, EMC Snap, EMC Storage Administrator, Acartus, Access Logix, ArchiveXtender, Authentic Problems, Automated Resource Manager, AutoStart, AutoSwap, AVALONidm, C-Clip, Celerra Replicator, CLARevent, Codebook Correlation Technology, Common Information Model, CopyCross, CopyPoint, DatabaseXtender, Direct Matrix, EDM, E-Lab, Engenuity, FarPoint, Global File Virtualization, Graphic Visualization, InfoMover, Infoscapes, MediaStor, MirrorView, NetWin, OnAlert, PowerSnap, RepliCare, SafeLine, SAN Advisor, SAN Copy, SAN Manager, SDMS, SnapImage, SnapSure, SnapView, StorageScope, SupportMate, SymmAPI, SymmEnabler, Symmetrix DMX, UltraPoint, UltraScale, Viewlets, and VisualSRM are trademarks of EMC Corporation.

All other trademarks used herein are the property of their respective owners.

Copyright © 1998-2008 EMC Corporation. All rights reserved.

Published May, 2008

EMC CLARiON CX3-20c (600 User) iSCSI with LCR Storage Solution for Microsoft Exchange Server 2007

Part Number: H4441.1

Table of Contents

Overview	4
Disclaimer	4
Features.....	4
Solution description	6
Targeted customer profile.....	8
Tested deployment	9
Simulated Exchange configuration.....	9
Primary storage hardware	10
Primary storage software.....	10
Primary storage disk configuration (mailbox store disks).....	11
Primary storage disk configuration (transactional log disks).....	11
Streaming backup.....	11
Disk configuration (streaming backup to disk).....	11
Best practices	12
Core storage/replication.....	12
Backup strategy	12
Test result summary	13
Reliability	13
Primary storage performance results	13
Individual server metrics.....	13
Streaming backup performance	14
Database read-only performance.....	14
Log read-only performance	14
Backup-to-disk performance.....	14
Conclusion	15
Contact information	15
Microsoft Exchange Server Jetstress 2-hour performance test results.....	16
Performance test result report	16
Microsoft Exchange Server Jetstress	19
Test result report.....	19
Microsoft Exchange Server Jetstress 24-hour performance test results.....	21
Stress test result report.....	21
Microsoft Exchange Server Jetstress	24
Test result report.....	24
Microsoft Exchange Server Jetstress soft recovery test results.....	26
Soft recovery test result report	26
Microsoft Exchange Server Jetstress	29
Soft recovery test result report	29
Microsoft Exchange Server Jetstress streaming backup test results.....	31
Streaming backup test result report.....	31

Overview

This document provides information on EMC's CLARiiON® CX3-20c (600 user) iSCSI with Local Continuous Replication (LCR) Storage Solution for Microsoft Exchange Server 2007, which is based on the *Microsoft Exchange Solution Reviewed Program (ESRP) – Storage program**. For any questions or comments regarding the contents of this document, see the Contact information section.

*The *ESRP – Storage* program was developed by Microsoft Corporation to provide a common storage testing framework for EMC and to provide information on its storage solutions for the Microsoft Exchange Server software. For more details on the *Microsoft ESRP – Storage* program, please visit: <http://www.microsoft.com/technet/prodtechnol/exchange/2007/esrp.msp>

Disclaimer

This document has been produced independently of Microsoft Corporation. Microsoft Corporation expressly disclaims responsibility for, and makes no warranty, express or implied, with respect to, the accuracy of the contents of this document.

The information contained in this document represents the current view of EMC on the issues discussed as of the date of publication. Due to the changing market conditions, it should not be interpreted to be a commitment on the part of EMC, and EMC cannot guarantee the accuracy of any information presented after the date of publication.

Features

This document describes an approach that can be used to configure Exchange solutions for LCR around EMC's CLARiiON CX3-20c storage systems. Built on the innovative EMC® CLARiiON CX3 UltraScale™ architecture, the EMC CX3-20c offers exceptional performance, ease of use, and unmatched reliability. It meets the storage needs of a wide range of applications including:

- Mail / Messaging
- Databases
- File, print, and Web services
- Distributed applications
- Remote replication

In addition, the CX3-20c supports a wide range of server operating environments such as: Microsoft Windows, Linux, Solaris, AIX, HP-UX, and VMware ESX Server.

EMC's CLARiiON CX3-20c Fibre Channel (FC) / iSCSI array offers 4 GB/s FC and 1 GB/s iSCSI ports that are fully integrated in the same array, enabling customers to leverage their networked storage investments over a broader range of servers and applications with complete flexibility without additional hardware. A total of eight iSCSI ports (four per SP) and four FC ports (two per SP) are available on each CX3-20c array.

The CLARiiON CX3-20c FC / iSCSI array provides customers with an advantage, irrespective of whether they have iSCSI or FC deployed. For customers who are implementing networked storage for the first time and are considering iSCSI, the CLARiiON CX3-20c FC / iSCSI array provides scalable iSCSI storage as well as the flexibility and investment protection of integrated FC support.

For customers with existing FC deployments, the CX3-20c FC / iSCSI array offers the opportunity to expand the reach of their networked storage environment economically with iSCSI, while maintaining complete flexibility with how the incremental capacity is shared across server platforms and interconnects.

With the CX3-20c FC / iSCSI array, customers can choose drive options that meet their specific needs, thereby providing multiple levels of performance in one system. The CX3-20c supports both high-performance and high-capacity disk drives in the same system; it can scale from 365 GB to 59 TB, and can support 128 high-availability hosts.

It supports 4 GB/s (15k rpm) FC drives for demanding applications that require maximum performance. Customers can also choose from 2 GB/s FC (10k rpm) for applications that require balanced performance and costs. Alternatively, customers have the option to choose low-cost 2 GB/s FC drives (7.2k rpm) for Tier 2 applications that require high-capacity and low cost, such as disk-based backup.

The CX3-20c delivers tiered storage that allows customers to provide the right level of performance to the right applications. The system also delivers an exceptional 4 GB/s of performance throughout the entire system without compromises or bottlenecks. Performance-boosting features include four front-end and two back-end 4 GB/s ports, plus state-of-the art low latency, high bandwidth I/O interconnect technologies.

The performance results and best practices discussed in this document provide tested guidelines for configuring the CX3-20c for a high-performance Exchange environment. For this solution, an EMC CLARiiON CX3-20c Storage Solution for Microsoft Exchange Server was used and configured for 600 Exchange 2007 users with LCR enabled for all storage groups within the solution.

The server was connected to the CX3-20c through dedicated NICs (used for iSCSI) with the Microsoft iSCSI Software Initiator 2.0.5, and an iSCSI VLAN. Each of the 600 users had a profile of .42 IOPS with a 600 MB mailbox requirement.

Solution description

The solution described is for one CX3-20c array with a single disk-array enclosure (DAE) using four drives for storage group database files, four drives for storage group log files (both in a 2+2 RAID 10 configuration), and five drives for streaming backup in a RAID 5 configuration. One hot spare drive is for active database storage. An additional eight disks are used for LCR of the storage group databases and logs, with each in a 2+2 RAID 10 configuration.

The active and passive database drives are placed on drives 0_10-0_13 on the first and second DAE. Log files for the active and passive drives are placed on the first four drives 0_0-0_3, with each in a RAID 10 configuration. Streaming backup drives are placed on the 0_5-0_9 in a RAID 5 configuration, and drive 0_14 is configured as a dedicated hot spare.

Sizing and configuring storage for use with Microsoft Exchange Server is a complicated process, driven by many variables and factors that vary from one organization to another.

The sizing method described in this ESRP submission is known as the “building block,” which is used to simplify sizing and configuration when using a low number of disks to ensure the highest performance while remaining fault tolerant.

This unit of measure (or building block) is designed to be scalable - based on customer I/O and latency requirements. The building blocks are designed around the Exchange database drives in four-drive increments using RAID 1_0. The Exchange log files are placed onto a four-drive RAID 1_0 configuration that is capable of holding multiple building blocks of storage group log files.

The building block is also designed to expand into larger building block deployments. These deployments are detailed in EMC ESRP submission documents (for over 4,000 users) on EMC.com.

Figure 1 illustrates the building block layout for this ESRP submission.

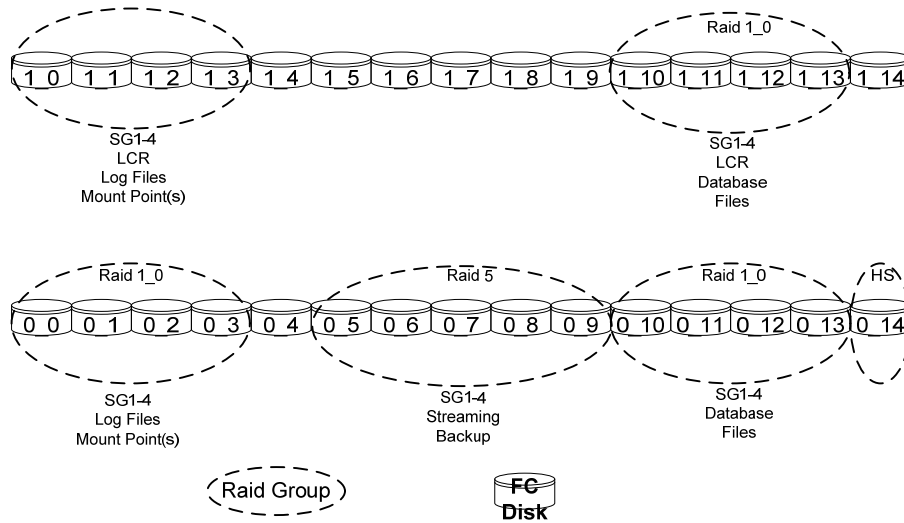

Figure 1 Building block layout

Figure 2 illustrates the physical architecture for the ESRP submission.

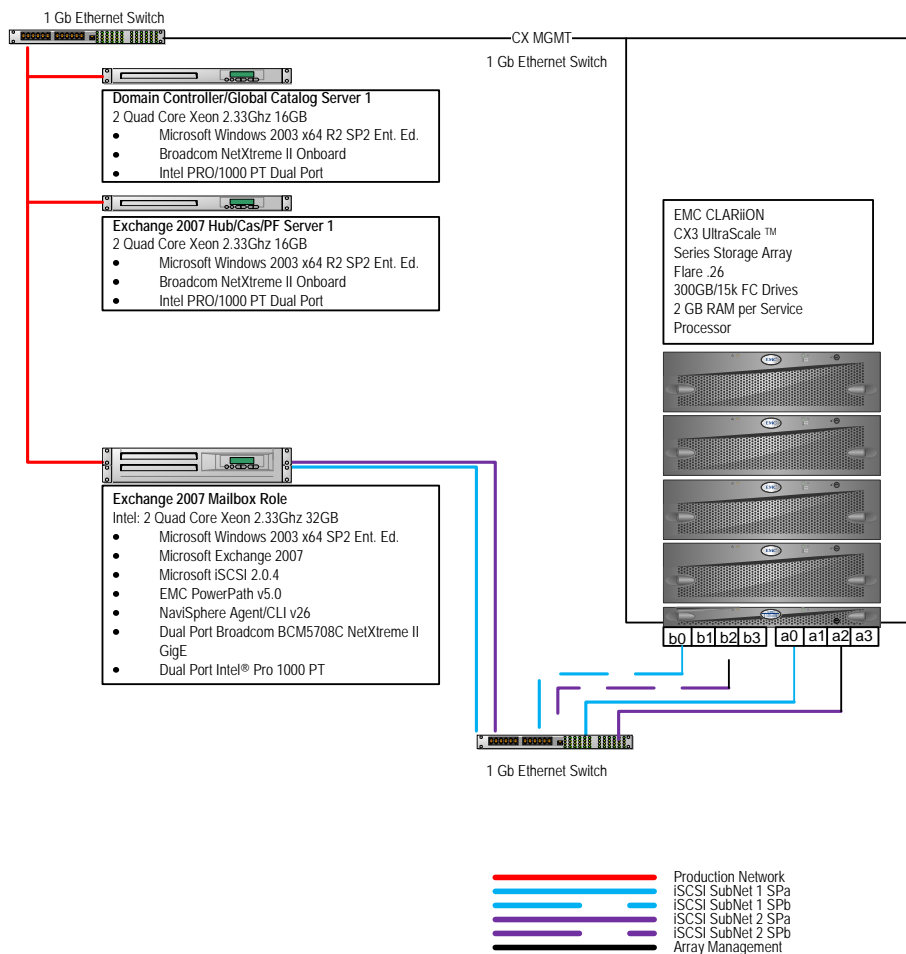

Figure 2 Physical architecture

The ESRP-Storage program focuses on storage solution testing to address performance and reliability issues with storage design. However, storage is not the only factor to take into consideration when scaling for an Exchange solution. Other factors that affect server scalability are:

- Server processor utilization
- Server physical and virtual memory limitations
- Resource requirements for other applications
- Directory and network service latencies
- Network infrastructure limitations
- Replication and recovery requirements
- Client usage profiles

All these factors are beyond the scope of ESRP-Storage. Therefore, the number of mailboxes hosted per server as part of the tested configuration may not necessarily be viable for some customer deployments.

For more information on identifying and addressing performance bottlenecks in an Exchange system, please refer to Microsoft's *Troubleshooting Microsoft Exchange Server Performance*, available at:

<http://go.microsoft.com/fwlink/?LinkId=23454>

Targeted customer profile

This solution is intended for small- and medium-sized businesses hosting 600 Exchange mailboxes. The configuration used for testing is as below:

- Number of mailbox servers presented to the storage array = 1
- User I/O profile for testing = 0.42
- User mailbox size for testing = 600 MB
- Backup strategy for testing = streaming backup to disk
- Time for restore = less than 3 hours per SG and 100 GB database per SG tested
- Requirements for Local Continuous Replication (LCR)

Tested deployment

The following tables summarize the testing environment

Simulated Exchange configuration

Item	Description
Number of Exchange mailboxes simulated	600
Number of hosts	1
Number of mailboxes/host	600
Number of storage groups/host	4
Number of mailbox stores/storage group	1
Number of mailboxes/mailbox store	150
Number of mailbox store LUNs/storage group	1
Simulated profile: I/Os per second per mailbox (IOPS, include 20% headroom)	0.5
Database LUN size	120 GB
Log LUN size	12 GB
Backup LUN size/storage group	Not applicable
Total database size for performance testing	100 GB
% Storage capacity used by Exchange database**	80%

**Storage performance characteristics change based on the percentage utilization of the individual disks. Tests that use a small percentage of the storage (~25%) may exhibit reduced throughput if the storage capacity utilization is significantly increased beyond what is tested in this paper.

Primary storage hardware

Item	Description
Storage connectivity (Fibre Channel, SAS, SATA, iSCSI)	iSCSI
Storage model and OS/firmware revision	CX3-20c FLARE® 26
Storage cache	2 GB/SP
Number of storage controllers	2
Number of storage ports	4 tested – 8 possible
Maximum bandwidth of storage connectivity to host	4*1 Gb per SP
Switch type/model/firmware revision	Dell 5324 version 2.0.0.39
HBA model and firmware	Intel PRO/1000 PT Dual Port Server Adapter
Number of HBAs/host	2
Host server type	Dell PowerEdge 2950 4: Dual Core [01]: EM64T Family 6 Model 15 Stepping 7 GenuineIntel ~2328 Mhz [02]: EM64T Family 6 Model 15 Stepping 7 GenuineIntel ~2328 Mhz [03]: EM64T Family 6 Model 15 Stepping 7 GenuineIntel ~2328 Mhz [04]: EM64T Family 6 Model 15 Stepping 7 GenuineIntel ~2328 Mhz [05]: EM64T Family 6 Model 15 Stepping 7 GenuineIntel ~2328 Mhz [06]: EM64T Family 6 Model 15 Stepping 7 GenuineIntel ~2328 Mhz [07]: EM64T Family 6 Model 15 Stepping 7 GenuineIntel ~2328 Mhz [08]: EM64T Family 6 Model 15 Stepping 7 GenuineIntel ~2328 Mhz
Total number of disks tested in solution	14 with hotspare
Maximum number of spindles that can be hosted in the storage	15

Primary storage software

Item	Description
HBA driver	c:\windows\system32\drivers\le5132.sys 9.9.13.0 built by: winDDK 6/19/2007 10:47am 348,568
HBA QueueTarget Setting	Not applicable
HBA QueueDepth Setting	Not applicable
Multi-Pathing	Microsoft iSCSI Initiator 2.0 Build 3392 EMC powermt for PowerPath® 5.0.0 (build 94)
Host OS	Microsoft Windows Server 2003 Enterprise x64 Edition OS Version: 5.2.3790 Service Pack 2
ESE.dll file version	08.00.0685.024
Replication solution name/version	Not applicable

Primary storage disk configuration (mailbox store disks)

Item	Description
Disk type, speed and firmware revision	FC SCSI: 4 GB/s, 15,000 rpm, 630A
Raw capacity per disk (GB)	268.403 GB
Number of physical disks in test	4
Total raw storage capacity (GB)	1073.612 GB
Disk slice size (GB)	Not applicable
Number of slices per LUN or number of disks per LUN	Not applicable
Number of LUNs per RAID Group	4
LUN size in GB	120
RAID level	RAID 1_0
Total formatted capacity	480 GB
Storage capacity utilization	44%
Database capacity utilization	80%

Primary storage disk configuration (transactional log disks)

Item	Description
Disk type, speed and firmware revision	FC SCSI: 4 GB/s, 15,000 rpm, 630A
Raw capacity per disk (GB)	268.403 GB
Number of spindles in test	4
Total raw storage capacity (GB)	1073.612 GB
Disk slice size (GB)	Not applicable
Number of slices per LUN or number of disks per LUN	Not applicable
Number of LUNs per RAID Group	4
LUN size in GB	12
RAID level	RAID 1_0
Total formatted capacity	48 GB

Streaming backup

Disk configuration (streaming backup to disk)

Item	Description
Disk type, speed and firmware revision	FC SCSI: 4 GB/s, 15,000 rpm, 630A
Raw capacity per disk (GB)	268.403 GB
Number of spindles in test	5
Total raw storage capacity (GB)	1342.015 GB
Disk slice size (GB)	Not applicable
Number of slices per LUN or number of disks per LUN	Not applicable
Number of LUNs per RAID Group	1
RAID level	RAID 5
Total formatted capacity	1073.612 GB

Best practices

Microsoft Exchange Server is a disk-intensive application. Based on the testing that is run using the ESRP framework, EMC recommends Exchange 2007 best practices to improve storage performance.

For Exchange 2007 best practices on storage design, refer to:
<http://technet.microsoft.com/en-us/library/bb124518.aspx>

Core storage/replication

1. Use diskpart (in Microsoft Windows 2003 SP2 x64) to align all disks used with Microsoft Exchange, using a value of 64 for CLARiiON. This aligns all of the Exchange-related NTFS partitions on a 64 KB boundary.
2. Isolate the Microsoft Exchange database workload from other I/O intensive applications or workloads. This ensures the highest levels of performance for Microsoft Exchange and makes troubleshooting efforts easier in the event of a disk-related Microsoft Exchange performance issue.
3. TcpAckFrequency = 1 for each iSCSI connection. Refer to:
<http://support.microsoft.com/kb/328890>.
4. Size and configure the environment for spindle performance as a primary consideration, with storage capacity as secondary.
5. iSCSI configuration with PowerPath 5.0 uses a balanced path approach. Log in with NIC0 to A0(SPa) and B0(SPb), NIC1 to A2(SPa) and B2(SPb).
6. Tuning the CX3-20c storage system parameters is important for obtaining best performance. The following list details the optimal parameters for Exchange:
 - Cache page size of 8 KB
 - Balance read and write caching
 - Read and write cache enabled for all LUNs
 - Read cache minimum of 50 - 100 MB for prefetch

See the following Microsoft documentation for storage-based replication best practices and support criteria:

Deployment Guidelines for Data Replication:

<http://www.microsoft.com/technet/prodtechnol/exchange/guides/E2k3DataRepl/bedf62a9-dff7-49a8-bd27-b2f1c46d5651.msp>

Multi-site data replication support for Exchange:

<http://support.microsoft.com/?kbid=895847>

Backup strategy

This solution used RAID 5 for the backup-to-disk LUNs (to maximize space), and then used EMC NetWorker[®] or NTBackup for backup to CDL or tape for long-term storage of databases.

Test result summary

This section provides a high-level summary of the test data from ESRP. The [Microsoft Exchange Server Jetstress 2-hour performance test results](#), [Microsoft Exchange Server Jetstress 24-hour performance test results](#), [Microsoft Exchange Server Jetstress soft recovery test results](#), and the [Microsoft Exchange Server Jetstress streaming backup test results](#) contain detailed HTML reports that are generated by the ESRP testing framework.

Reliability

A number of tests in the framework are to check the 24-hour reliability tests. The goal is to verify that the storage can handle high I/O load for a long period of time. Both the log and database files are analyzed for integrity after the stress test to ensure there was no database or log corruption.

- No errors reported in the saved eventlog file
- No errors reported during the database and log
- Event ID: 215 as expected at the end of the Jetstress run for streaming backup
- No errors during database checksum on the remote storage database

Primary storage performance results

The primary storage performance testing is designed to exercise the storage with the maximum sustainable Exchange type of I/O for 2 hours. The test is to show how long it takes for the storage to respond to an I/O under load. The data below is the sum of all logical disk I/Os, and the average of all the logical disk I/O latency in the 2-hour test duration. Each server is listed separately and the aggregate numbers across all servers is also listed.

Individual server metrics

The following table details the sum of I/O across storage groups and the average latency across all storage groups on a per server basis.

Database I/O	
Average database disk transfers/sec	322.828
Average database disk reads/sec	160.699
Average database disk writes/sec	162.129
Average database disk read latency (ms)	0.0085
Average database disk write latency (ms)	0.003
Transaction log I/O	
Average log disk writes/sec	114.901
Average log disk write latency (ms)	0.001

Streaming backup performance

For the 1.0 release, only streaming backup is supported for framework testing. There are two tests in this section: the first test is to measure the read I/O performance metrics by running checksum on all the databases and log files, the second test is to measure the end-to-end performance when the databases are backed up to disks.

Database read-only performance

This test is to measure the maximum rate for the databases (streaming backup). The following table shows the average rate for a single database file.

Item	Description
MB read/sec per storage group	10.245
MB read/sec total	40.98
File size/sec taken	387947.08/37889

Log read-only performance

This test is to measure the maximum rate that the log files can be played against the databases. The following table shows the average rate for 500 log files played in a single storage group. Each log file is 1 MB in size.

Item	Description
Average time to play one log file (s)	0.551669121

Backup-to-disk performance

This test runs a backup on all the database files, and stores them on disks. The following table lists the average rate that each storage group can be backed up.

Item	Description
Total database size per storage group (GB)	378.8545703
Time taken to back up each storage group	2:37:52
Average MB backed up/sec per storage group	10.24574459

Conclusion

This document has been developed by EMC, and reviewed by the Microsoft Exchange Product team. The test results/data presented in this document are based on the tests introduced in the ESRP test framework. The customers should not quote the data directly for their predeployment verification. It is still necessary to go through the exercises to validate the storage design for a specific customer environment.

The ESRP program is not designed to be a benchmark program; tests are not designed to get the maximum throughput for a given solution. Rather, it is focused on producing recommendations from vendors for the Exchange application. Therefore, the data presented in this document should not be used for direct comparisons among the solutions.

Contact information

EMC recommends that you consult with EMC Professional Services to assist with the design and deployment of a similar solution. For information regarding this or any other EMC Solution, please use the following numbers:

United States: (800) 782-4362 (SVC-4EMC)

Canada: (800) 543-4782 (543-4SVC)

Worldwide: (508) 497-7901

For additional information on EMC products and services available to customers and partners, please refer to:

<http://EMC.com> or <http://powerlink.EMC.com>

Microsoft Exchange Server Jetstress 2-hour performance test results

Performance test result report

Test summary

Overall Test **Pass**

Result

Machine Name 6TTRGD1

Test Description

Test Start Time 10/11/2007 4:23:26 AM

Test End Time 10/11/2007 6:41:36 AM

Jetstress Version 08.01.0177.000

Ese Version 08.00.0685.024

Operating System Microsoft Windows Server 2003 R2 Service Pack 2 (5.2.3790.131072)

Performance Log C:\Q4\Jetstress\4SG\1t\perf4-with evt cleared\Performance_2007_10_11_4_23_35.blg
C:\Q4\Jetstress\4SG\1t\perf4-with evt cleared\DBChecksum_2007_10_11_6_41_36.blg

Database sizing and throughput

Achieved I/O per Second 322.826

Capacity Percentage 100%

Throughput Percentage 100%

Initial database size 412311683072

Final database size 415792955392

Database files (count) 4

Jetstress system parameters

Thread count 1 (per-storage group)

Log buffers 9000

Minimum database cache 128.0 MB

Maximum database cache 1024.0 MB

Insert operations 25%

Delete operations 10%

Replace operations 50%

Read operations 15%

Lazy commits 80%

Disk subsystem performance

LogicalDisk	Avg. Disk sec/Read	Avg. Disk sec/Write	Disk Reads/sec	Disk Writes/sec	Avg. Disk Bytes/Write
Database (t:\sg1db)	0.009	0.003	39.605	40.455	(n/a)
Database (t:\sg2db)	0.008	0.003	40.561	40.303	(n/a)
Database (s:\sg3db)	0.009	0.003	39.784	41.171	(n/a)
Database (s:\sg4db)	0.008	0.003	40.749	40.200	(n/a)
Log (s:\sg1lg)	0.000	0.001	0.000	28.779	9807.859
Log (s:\sg2lg)	0.000	0.001	0.000	28.359	9857.304
Log (t:\sg3lg)	0.000	0.001	0.000	28.836	10077.139
Log (t:\sg4lg)	0.000	0.001	0.000	28.927	9833.654

Host system performance

Counter	Average	Minimum	Maximum
% Processor Time	0.741	0.000	1.263
Available MBytes	14711.892	14708.000	14812.000
Free System Page Table Entries	16758305.167	16758291.000	16758311.000
Transition Pages RePurposed/sec	0.000	0.000	0.000
Pool Nonpaged Bytes	57287722.667	57053184.000	57499648.000
Pool Paged Bytes	42541465.600	42508288.000	42573824.000
Database Page Fault Stalls/sec	0.000	0.000	0.000

Test Log

10/11/2007 4:23:25 AM -- Command Line: "C:\PROGRA~1\EXCHAN~1\jetstresscmd.exe" /c "C:\Q4\Jetstress\4SG\1t\perf4-with evt cleared\Perf.xml"

10/11/2007 4:23:25 AM -- Jetstress testing begins ...

10/11/2007 4:23:26 AM -- Prepare testing begins ...

10/11/2007 4:23:30 AM -- Attaching databases ...

10/11/2007 4:23:30 AM -- Prepare testing ends.

10/11/2007 4:23:30 AM -- Dispatching transactions begins ...

10/11/2007 4:23:30 AM -- Database cache settings: (minimum: 128.0 MB, maximum: 1.0 GB)

10/11/2007 4:23:30 AM -- Database flush thresholds: (start: 10.2 MB, stop: 20.5 MB)

10/11/2007 4:23:35 AM -- Database read latency thresholds: (average: 0.02 seconds/read, maximum: 0.05 seconds/read).

10/11/2007 4:23:35 AM -- Log write latency thresholds: (average: 0.01 seconds/write, maximum: 0.05 seconds/write).

10/11/2007 4:23:36 AM -- Operation mix: Sessions 1, Inserts 25%, Deletes 10%, Replaces 50%, Reads 15%, Lazy Commits 80%.

10/11/2007 4:23:36 AM -- Performance logging begins (interval: 15000 ms).

10/11/2007 4:23:36 AM -- Attaining prerequisites:

10/11/2007 4:41:31 AM -- \Database(JetstressCmd)\Database Cache Size, Last: 966516700.0

(lower bound: 966367600.0, upper bound: none)
10/11/2007 6:41:33 AM -- Performance logging ends.
10/11/2007 6:41:33 AM -- JetInterop batch transaction stats: 20771, 20766, 20746, and 21000.
10/11/2007 6:41:33 AM -- Dispatching transactions ends.
10/11/2007 6:41:33 AM -- Shutting down databases ...
10/11/2007 6:41:36 AM -- Instance636.1 (complete), Instance636.2 (complete), Instance636.3 (complete), and Instance636.4 (complete)
10/11/2007 6:41:36 AM -- Performance logging begins (interval: 15000 ms).
10/11/2007 6:41:36 AM -- Verifying database checksums ...
10/11/2007 7:36:32 AM -- t:\sg1db (100% processed), t:\sg2db (100% processed), s:\sg3db (100% processed), and s:\sg4db (100% processed)
10/11/2007 7:36:33 AM -- Performance logging ends.
10/11/2007 7:36:33 AM -- [C:\Q4\Jetstress\4SG\1t\perf4-with evt cleared\DBChecksum 2007 10 11 6 41 36.blg](#) has 219 samples.
10/11/2007 7:36:37 AM -- [C:\Q4\Jetstress\4SG\1t\perf4-with evt cleared\DBChecksum 2007 10 11 6 41 36.html](#) is saved.
10/11/2007 7:36:37 AM -- Verifying log checksums ...
10/11/2007 7:36:42 AM -- s:\sg1lg (22 logs passed), s:\sg2lg (21 logs passed), t:\sg3lg (22 logs passed), and t:\sg4lg (22 logs passed)
10/11/2007 7:36:42 AM -- [C:\Q4\Jetstress\4SG\1t\perf4-with evt cleared\Performance 2007 10 11 4 23 35.blg](#) has 551 samples.
10/11/2007 7:36:42 AM -- Creating test report ...
10/11/2007 7:36:46 AM -- Volume t:\sg1db has 0.0086 for Avg. Disk sec/Read.
10/11/2007 7:36:46 AM -- Volume t:\sg2db has 0.0078 for Avg. Disk sec/Read.
10/11/2007 7:36:46 AM -- Volume s:\sg3db has 0.0089 for Avg. Disk sec/Read.
10/11/2007 7:36:46 AM -- Volume s:\sg4db has 0.0080 for Avg. Disk sec/Read.
10/11/2007 7:36:46 AM -- Volume s:\sg1lg has 0.0009 for Avg. Disk sec/Write.
10/11/2007 7:36:46 AM -- Volume s:\sg1lg has 0.0000 for Avg. Disk sec/Read.
10/11/2007 7:36:46 AM -- Volume s:\sg2lg has 0.0009 for Avg. Disk sec/Write.
10/11/2007 7:36:46 AM -- Volume s:\sg2lg has 0.0000 for Avg. Disk sec/Read.
10/11/2007 7:36:46 AM -- Volume t:\sg3lg has 0.0009 for Avg. Disk sec/Write.
10/11/2007 7:36:46 AM -- Volume t:\sg3lg has 0.0000 for Avg. Disk sec/Read.
10/11/2007 7:36:46 AM -- Volume t:\sg4lg has 0.0009 for Avg. Disk sec/Write.
10/11/2007 7:36:46 AM -- Volume t:\sg4lg has 0.0000 for Avg. Disk sec/Read.
10/11/2007 7:36:46 AM -- Test has 0 Maximum Database Page Fault Stalls/sec.
10/11/2007 7:36:46 AM -- Test has 0 Database Page Fault Stalls/sec samples higher than 0.
10/11/2007 7:36:46 AM -- [C:\Q4\Jetstress\4SG\1t\perf4-with evt cleared\Performance 2007 10 11 4 23 35.xml](#) has 479 samples queried.

Microsoft Exchange Server Jetstress

Test result report

Checksum statistics - All

Database	Seen pages	Bad pages	Correctable pages	Wrong page no pages	File length / seconds taken
t:\sg1db\Jetstress1.edb	12689506	0	0	0	99136 MBytes / 3099 seconds
t:\sg2db\Jetstress1.edb	12688482	0	0	0	99128 MBytes / 3295 seconds
s:\sg3db\Jetstress1.edb	12693346	0	0	0	99166 MBytes / 3276 seconds
s:\sg4db\Jetstress1.edb	12684642	0	0	0	99098 MBytes / 2707 seconds
(Sum)	50755976	0	0	0	396531 MBytes / 3295 seconds

Disk subsystem performance (of checksum)

LogicalDisk	Avg. Disk sec/Read	Avg. Disk sec/Write	Disk Reads/sec	Disk Writes/sec
t:\sg1db	0.141	0.002	512.579	0.003
t:\sg2db	0.154	0.002	477.726	0.001
s:\sg3db	0.148	0.001	483.807	0.001
s:\sg4db	0.142	0.003	588.321	0.004

Memory system performance (of checksum)

Counter	Average	Minimum	Maximum
% Processor Time	9.221	5.528	10.768
Available MBytes	15546.694	15524.000	15727.000
Free System Page Table Entries	16758061.320	16758061.000	16758131.000
Transition Pages RePurposed/sec	0.000	0.000	0.000
Pool Nonpaged Bytes	79216864.438	74141696.000	80797696.000
Pool Paged Bytes	42636947.288	42610688.000	43163648.000

Test Log

10/11/2007 4:23:25 AM -- Command Line: "C:\PROGRA~1\EXCHAN~1\jetstresscmd.exe" /c "C:\Q4\Jetstress\4SG\1t\perf4-with evt cleared\Perf.xml"
10/11/2007 4:23:25 AM -- Jetstress testing begins ...
10/11/2007 4:23:26 AM -- Prepare testing begins ...
10/11/2007 4:23:30 AM -- Attaching databases ...
10/11/2007 4:23:30 AM -- Prepare testing ends.
10/11/2007 4:23:30 AM -- Dispatching transactions begins ...
10/11/2007 4:23:30 AM -- Database cache settings: (minimum: 128.0 MB, maximum: 1.0 GB)
10/11/2007 4:23:30 AM -- Database flush thresholds: (start: 10.2 MB, stop: 20.5 MB)

10/11/2007 4:23:35 AM -- Database read latency thresholds: (average: 0.02 seconds/read, maximum: 0.05 seconds/read).
10/11/2007 4:23:35 AM -- Log write latency thresholds: (average: 0.01 seconds/write, maximum: 0.05 seconds/write).
10/11/2007 4:23:36 AM -- Operation mix: Sessions 1, Inserts 25%, Deletes 10%, Replaces 50%, Reads 15%, Lazy Commits 80%.
10/11/2007 4:23:36 AM -- Performance logging begins (interval: 15000 ms).
10/11/2007 4:23:36 AM -- Attaining prerequisites:
10/11/2007 4:41:31 AM -- \Database(JetstressCmd)\Database Cache Size, Last: 966516700.0 (lower bound: 966367600.0, upper bound: none)
10/11/2007 6:41:33 AM -- Performance logging ends.
10/11/2007 6:41:33 AM -- JetInterop batch transaction stats: 20771, 20766, 20746, and 21000.
10/11/2007 6:41:33 AM -- Dispatching transactions ends.
10/11/2007 6:41:33 AM -- Shutting down databases ...
10/11/2007 6:41:36 AM -- Instance636.1 (complete), Instance636.2 (complete), Instance636.3 (complete), and Instance636.4 (complete)
10/11/2007 6:41:36 AM -- Performance logging begins (interval: 15000 ms).
10/11/2007 6:41:36 AM -- Verifying database checksums ...
10/11/2007 7:36:32 AM -- t:\sg1db (100% processed), t:\sg2db (100% processed), s:\sg3db (100% processed), and s:\sg4db (100% processed)
10/11/2007 7:36:33 AM -- Performance logging ends.
10/11/2007 7:36:33 AM -- [C:\Q4\Jetstress\4SG\1t\perf4-with evt cleared\DBChecksum 2007 10 11 6 41 36.blg](#) has 219 samples.

Microsoft Exchange Server Jetstress 24-hour performance test results

Stress test result report

Test summary

Overall Test Result **Pass**

Machine Name 6TTRGD1

Test Description

Test Start Time 10/28/2007 7:17:10 AM

Test End Time 10/29/2007 7:52:28 AM

Jetstress Version 08.01.0177.000

Ese Version 08.00.0685.024

Operating System Microsoft Windows Server 2003 R2 Service Pack 2 (5.2.3790.131072)

Performance Log G:\Itstress\Stress_2007_10_28_7_17_23.blg

G:\Itstress\DBChecksum_2007_10_29_7_52_28.blg

Database sizing and throughput

Achieved I/O per Second 189.287

Capacity Percentage 100%

Throughput Percentage 100%

Initial database size 412311683072

Final database size 431920054272

Database files (count) 4

Jetstress system parameters

Thread count 1 (per-storage group)

Log buffers 9000

Minimum database cache 128.0 MB

Maximum database cache 1024.0 MB

Insert operations 25%

Delete operations 10%

Replace operations 50%

Read operations 15%

Lazy commits 80%

Disk subsystem performance

LogicalDisk	Avg. Disk sec/Read	Avg. Disk sec/Write	Disk Reads/sec	Disk Writes/sec	Avg. Disk Bytes/Write
Database (T:\SG1DB)	0.009	0.074	24.129	23.181	(n/a)
Database (T:\SG2DB)	0.008	0.071	23.979	23.201	(n/a)
Database (S:\SG3DB)	0.009	0.081	24.048	23.266	(n/a)
Database (S:\SG4DB)	0.008	0.074	24.042	23.441	(n/a)
Log (S:\SG1LG)	0.000	0.006	0.000	15.457	9956.415
Log (S:\SG2LG)	0.000	0.006	0.000	15.389	10028.980
Log (T:\SG3LG)	0.000	0.006	0.000	15.470	10027.435
Log (T:\SG4LG)	0.000	0.006	0.000	15.562	10064.258

Host system performance

Counter	Average	Minimum	Maximum
% Processor Time	0.534	0.182	2.083
Available MBytes	14709.911	14694.000	14819.000
Free System Page Table Entries	16758188.688	16758181.000	16758191.000
Transition Pages RePurposed/sec	0.000	0.000	0.000
Pool Nonpaged Bytes	58730065.067	58474496.000	59023360.000
Pool Paged Bytes	42400385.422	41926656.000	43311104.000
Database Page Fault Stalls/sec	0.000	0.000	0.000

Test Log

10/28/2007 7:17:09 AM -- Command Line: "C:\PROGRA~1\EXCHAN~1\jetstresscmd.exe" /c "G:\1tstress\stress.xml"

10/28/2007 7:17:10 AM -- Jetstress testing begins ...

10/28/2007 7:17:10 AM -- Prepare testing begins ...

10/28/2007 7:17:17 AM -- Attaching databases ...

10/28/2007 7:17:17 AM -- Prepare testing ends.

10/28/2007 7:17:17 AM -- Dispatching transactions begins ...

10/28/2007 7:17:17 AM -- Database cache settings: (minimum: 128.0 MB, maximum: 1.0 GB)

10/28/2007 7:17:17 AM -- Database flush thresholds: (start: 10.2 MB, stop: 20.5 MB)

10/28/2007 7:17:23 AM -- Database read latency thresholds: (average: 0.02 seconds/read, maximum: 0.1 seconds/read).

10/28/2007 7:17:23 AM -- Log write latency thresholds: (average: 0.01 seconds/write, maximum: 0.1 seconds/write).

10/28/2007 7:17:24 AM -- Operation mix: Sessions 1, Inserts 25%, Deletes 10%, Replaces 50%, Reads 15%, Lazy Commits 80%.

10/28/2007 7:17:24 AM -- Performance logging begins (interval: 15000 ms).

10/28/2007 7:17:24 AM -- Attaining prerequisites:

10/28/2007 7:51:41 AM -- \Database(JetstressCmd)\Database Cache Size, Last: 966475800.0
 (lower bound: 966367600.0, upper bound: none)
 10/29/2007 7:51:43 AM -- Performance logging ends.
 10/29/2007 7:51:43 AM -- JetInterop batch transaction stats: 118347, 118336, 118656, and
 119198.
 10/29/2007 7:51:43 AM -- Dispatching transactions ends.
 10/29/2007 7:51:43 AM -- Shutting down databases ...
 10/29/2007 7:52:28 AM -- Instance2512.1 (complete), Instance2512.2 (complete),
 Instance2512.3 (complete), and Instance2512.4 (complete)
 10/29/2007 7:52:29 AM -- Performance logging begins (interval: 15000 ms).
 10/29/2007 7:52:29 AM -- Verifying database checksums ...
 10/29/2007 8:48:19 AM -- T:\SG1DB (100% processed), T:\SG2DB (100% processed),
 S:\SG3DB (100% processed), and S:\SG4DB (100% processed)
 10/29/2007 8:48:20 AM -- Performance logging ends.
 10/29/2007 8:48:20 AM -- G:\Itstress\DBChecksum_2007_10_29_7_52_28.blg has 223 samples.
 10/29/2007 8:48:24 AM -- G:\Itstress\DBChecksum_2007_10_29_7_52_28.html is saved.
 10/29/2007 8:48:24 AM -- Verifying log checksums ...
 10/29/2007 8:48:30 AM -- S:\SG1LG (22 logs passed), S:\SG2LG (21 logs passed), T:\SG3LG
 (22 logs passed), and T:\SG4LG (22 logs passed)
 10/29/2007 8:48:30 AM -- G:\Itstress\Stress_2007_10_28_7_17_23.blg has 5897 samples.
 10/29/2007 8:48:30 AM -- Creating test report ...
 10/29/2007 8:49:23 AM -- Volume T:\SG1DB has 0.0087 for Avg. Disk sec/Read.
 10/29/2007 8:49:23 AM -- Volume T:\SG2DB has 0.0082 for Avg. Disk sec/Read.
 10/29/2007 8:49:23 AM -- Volume S:\SG3DB has 0.0089 for Avg. Disk sec/Read.
 10/29/2007 8:49:23 AM -- Volume S:\SG4DB has 0.0081 for Avg. Disk sec/Read.
 10/29/2007 8:49:23 AM -- Volume S:\SG1LG has 0.0058 for Avg. Disk sec/Write.
 10/29/2007 8:49:23 AM -- Volume S:\SG1LG has 0.0000 for Avg. Disk sec/Read.
 10/29/2007 8:49:23 AM -- Volume S:\SG2LG has 0.0057 for Avg. Disk sec/Write.
 10/29/2007 8:49:23 AM -- Volume S:\SG2LG has 0.0000 for Avg. Disk sec/Read.
 10/29/2007 8:49:23 AM -- Volume T:\SG3LG has 0.0057 for Avg. Disk sec/Write.
 10/29/2007 8:49:23 AM -- Volume T:\SG3LG has 0.0000 for Avg. Disk sec/Read.
 10/29/2007 8:49:23 AM -- Volume T:\SG4LG has 0.0058 for Avg. Disk sec/Write.
 10/29/2007 8:49:23 AM -- Volume T:\SG4LG has 0.0000 for Avg. Disk sec/Read.
 10/29/2007 8:49:23 AM -- Test has 0 Maximum Database Page Fault Stalls/sec.
 10/29/2007 8:49:23 AM -- Test has 0 Database Page Fault Stalls/sec samples higher than 0.
 10/29/2007 8:49:23 AM -- G:\Itstress\Stress_2007_10_28_7_17_23.xml has 5759 samples
 queried.

Microsoft Exchange Server Jetstress

Test result report

Checksum statistics - All

Database	Seen pages	Bad pages	Correctable pages	Wrong page no pages	File length / seconds taken
T:\SG1DB\Jetstress1.edb	13169250	0	0	0	102884 MBytes / 3189 seconds
T:\SG2DB\Jetstress1.edb	13178466	0	0	0	102956 MBytes / 3349 seconds
S:\SG3DB\Jetstress1.edb	13180514	0	0	0	102972 MBytes / 3332 seconds
S:\SG4DB\Jetstress1.edb	13196386	0	0	0	103096 MBytes / 2772 seconds
(Sum)	52724616	0	0	0	411911 MBytes / 3350 seconds

Disk subsystem performance (of checksum)

LogicalDisk	Avg. Disk sec/Read	Avg. Disk sec/Write	Disk Reads/sec	Disk Writes/sec
T:\SG1DB	0.137	0.003	516.710	0.002
T:\SG2DB	0.153	0.001	488.266	0.002
S:\SG3DB	0.146	0.001	495.159	0.002
S:\SG4DB	0.137	0.001	597.189	0.003

Memory system performance (of checksum)

Counter	Average	Minimum	Maximum
% Processor Time	9.758	8.203	13.125
Available MBytes	15545.000	15525.000	15725.000
Free System Page Table Entries	16758111.314	16758111.000	16758181.000
Transition Pages RePurposed/sec	0.000	0.000	0.000
Pool Nonpaged Bytes	80717888.287	75685888.000	81686528.000
Pool Paged Bytes	44029759.139	43769856.000	44322816.000

Test Log

10/28/2007 7:17:09 AM -- Command Line:

"C:\PROGRA~1\EXCHAN~1\jetstresscmd.exe" /c "G:\1tstress\stress.xml"

10/28/2007 7:17:10 AM -- Jetstress testing begins ...

10/28/2007 7:17:10 AM -- Prepare testing begins ...

10/28/2007 7:17:17 AM -- Attaching databases ...

10/28/2007 7:17:17 AM -- Prepare testing ends.

10/28/2007 7:17:17 AM -- Dispatching transactions begins ...

10/28/2007 7:17:17 AM -- Database cache settings: (minimum: 128.0 MB, maximum: 1.0 GB)

10/28/2007 7:17:17 AM -- Database flush thresholds: (start: 10.2 MB, stop: 20.5 MB)

10/28/2007 7:17:23 AM -- Database read latency thresholds: (average: 0.02 seconds/read, maximum: 0.1 seconds/read).
10/28/2007 7:17:23 AM -- Log write latency thresholds: (average: 0.01 seconds/write, maximum: 0.1 seconds/write).
10/28/2007 7:17:24 AM -- Operation mix: Sessions 1, Inserts 25%, Deletes 10%, Replaces 50%, Reads 15%, Lazy Commits 80%.
10/28/2007 7:17:24 AM -- Performance logging begins (interval: 15000 ms).
10/28/2007 7:17:24 AM -- Attaining prerequisites:
10/28/2007 7:51:41 AM -- \Database(JetstressCmd)\Database Cache Size, Last: 966475800.0 (lower bound: 966367600.0, upper bound: none)
10/29/2007 7:51:43 AM -- Performance logging ends.
10/29/2007 7:51:43 AM -- JetInterop batch transaction stats: 118347, 118336, 118656, and 119198.
10/29/2007 7:51:43 AM -- Dispatching transactions ends.
10/29/2007 7:51:43 AM -- Shutting down databases ...
10/29/2007 7:52:28 AM -- Instance2512.1 (complete), Instance2512.2 (complete), Instance2512.3 (complete), and Instance2512.4 (complete)
10/29/2007 7:52:29 AM -- Performance logging begins (interval: 15000 ms).
10/29/2007 7:52:29 AM -- Verifying database checksums ...
10/29/2007 8:48:19 AM -- T:\SG1DB (100% processed), T:\SG2DB (100% processed), S:\SG3DB (100% processed), and S:\SG4DB (100% processed)
10/29/2007 8:48:20 AM -- Performance logging ends.
10/29/2007 8:48:20 AM -- [G:\Itstress\DBChecksum 2007 10 29 7 52 28.blg](#) has 223 samples.

Microsoft Exchange Server Jetstress soft recovery test results

Soft recovery test result report

Test summary

Overall Test Result **Pass**

Machine Name 6TTRGD1

Test Description

Test Start Time 10/11/2007 7:53:32 PM

Test End Time 10/11/2007 8:57:50 PM

Jetstress Version 08.01.0177.000

Ese Version 08.00.0685.024

Operating System Microsoft Windows Server 2003 R2 Service Pack 2 (5.2.3790.131072)

Performance Log C:\Q4\Jetstress\4SG\1t\soft\Performance_2007_10_11_19_53_42.blg

Database sizing and throughput

Achieved I/O per Second 322.124

Capacity Percentage 100%

Throughput Percentage 100%

Initial database size 412311683072

Final database size 413949558784

Database files (count) 4

Jetstress system parameters

Thread count 1 (per-storage group)

Log buffers 9000

Minimum database cache 128.0 MB

Maximum database cache 1024.0 MB

Insert operations 25%

Delete operations 10%

Replace operations 50%

Read operations 15%

Lazy commits 80%

Disk subsystem performance

LogicalDisk	Avg. Disk sec/Read	Avg. Disk sec/Write	Disk Reads/sec	Disk Writes/sec	Avg. Disk Bytes/Write
Database (T:\SG1DB)	0.008	0.003	40.668	38.901	(n/a)
Database (T:\SG2DB)	0.008	0.003	41.288	39.943	(n/a)
Database (S:\SG3DB)	0.009	0.003	40.867	39.114	(n/a)
Database (S:\SG4DB)	0.008	0.003	41.165	40.178	(n/a)
Log (S:\SG1LG)	0.001	0.001	0.032	29.600	9640.031
Log (S:\SG2LG)	0.001	0.001	0.033	29.833	10130.359
Log (T:\SG3LG)	0.001	0.001	0.032	29.827	9866.105
Log (T:\SG4LG)	0.001	0.001	0.034	29.787	10132.623

Host system performance

Counter	Average	Minimum	Maximum
% Processor Time	0.961	0.000	12.773
Available MBytes	14848.438	14699.000	15722.000
Free System Page Table Entries	16758132.289	16758131.000	16758161.000
Transition Pages RePurposed/sec	0.000	0.000	0.000
Pool Nonpaged Bytes	58006480.000	56291328.000	58257408.000
Pool Paged Bytes	46266688.000	45547520.000	46657536.000
Database Page Fault Stalls/sec	0.000	0.000	0.000

Test Log

10/11/2007 7:53:32 PM -- Command Line:

"C:\PROGRA~1\EXCHAN~1\jetstresscmd.exe" /c "C:\Q4\Jetstress\4SG\1t\soft\soft.xml"

10/11/2007 7:53:32 PM -- Jetstress testing begins ...

10/11/2007 7:53:32 PM -- Prepare testing begins ...

10/11/2007 7:53:37 PM -- Attaching databases ...

10/11/2007 7:53:37 PM -- Prepare testing ends.

10/11/2007 7:53:37 PM -- Dispatching transactions begins ...

10/11/2007 7:53:37 PM -- Database cache settings: (minimum: 128.0 MB, maximum: 1.0 GB)

10/11/2007 7:53:37 PM -- Database flush thresholds: (start: 10.2 MB, stop: 20.5 MB)

10/11/2007 7:53:42 PM -- Database read latency thresholds: (average: 0.02 seconds/read, maximum: 0.05 seconds/read).

10/11/2007 7:53:42 PM -- Log write latency thresholds: (average: 0.01 seconds/write, maximum: 0.05 seconds/write).

10/11/2007 7:53:43 PM -- Operation mix: Sessions 1, Inserts 25%, Deletes 10%, Replaces 50%, Reads 15%, Lazy Commits 80%.

10/11/2007 7:53:43 PM -- Performance logging begins (interval: 15000 ms).

10/11/2007 7:53:43 PM -- Generating log files ...

10/11/2007 8:57:46 PM -- S:\SG1LG (100.2% generated), S:\SG2LG (103.2% generated),

T:\SG3LG (100.8% generated), and T:\SG4LG (103.8% generated)
10/11/2007 8:57:47 PM -- Performance logging ends.
10/11/2007 8:57:47 PM -- JetInterop batch transaction stats: 9830, 9973, 9934, and 9846.
10/11/2007 8:57:48 PM -- Dispatching transactions ends.
10/11/2007 8:57:48 PM -- Shutting down databases ...
10/11/2007 8:57:50 PM -- Instance1620.1 (complete), Instance1620.2 (complete), Instance1620.3 (complete), and Instance1620.4 (complete)
10/11/2007 8:57:50 PM -- C:\Q4\Jetstress\4SG\1t\soft\Performance_2007_10_11_19_53_42.blg has 256 samples.
10/11/2007 8:57:50 PM -- Creating test report ...
10/11/2007 8:57:51 PM -- Volume T:\SG1DB has 0.0081 for Avg. Disk sec/Read.
10/11/2007 8:57:51 PM -- Volume T:\SG2DB has 0.0078 for Avg. Disk sec/Read.
10/11/2007 8:57:51 PM -- Volume S:\SG3DB has 0.0089 for Avg. Disk sec/Read.
10/11/2007 8:57:51 PM -- Volume S:\SG4DB has 0.0076 for Avg. Disk sec/Read.
10/11/2007 8:57:51 PM -- Volume S:\SG1LG has 0.0008 for Avg. Disk sec/Write.
10/11/2007 8:57:51 PM -- Volume S:\SG1LG has 0.0008 for Avg. Disk sec/Read.
10/11/2007 8:57:51 PM -- Volume S:\SG2LG has 0.0009 for Avg. Disk sec/Write.
10/11/2007 8:57:51 PM -- Volume S:\SG2LG has 0.0006 for Avg. Disk sec/Read.
10/11/2007 8:57:51 PM -- Volume T:\SG3LG has 0.0009 for Avg. Disk sec/Write.
10/11/2007 8:57:51 PM -- Volume T:\SG3LG has 0.0009 for Avg. Disk sec/Read.
10/11/2007 8:57:51 PM -- Volume T:\SG4LG has 0.0009 for Avg. Disk sec/Write.
10/11/2007 8:57:51 PM -- Volume T:\SG4LG has 0.0010 for Avg. Disk sec/Read.
10/11/2007 8:57:51 PM -- Test has 0 Maximum Database Page Fault Stalls/sec.
10/11/2007 8:57:51 PM -- Test has 0 Database Page Fault Stalls/sec samples higher than 0.
10/11/2007 8:57:51 PM -- C:\Q4\Jetstress\4SG\1t\soft\Performance_2007_10_11_19_53_42.xml has 255 samples queried.

Microsoft Exchange Server Jetstress

Soft recovery test result report

Soft recovery statistics - All

Database Instance	Log files replayed	Elapsed seconds
Instance1620.1	500	282.5
Instance1620.2	515	278.25
Instance1620.3	504	288.5
Instance1620.4	518	274.5

Disk subsystem performance

LogicalDisk	Avg. Disk sec/Read	Avg. Disk sec/Write	Disk Reads/sec	Disk Writes/sec	Avg. Disk Bytes/Write
Database (T:\SG1DB)	0.086	0.027	406.978	7.139	(n/a)
Database (T:\SG2DB)	0.085	0.027	405.157	7.414	(n/a)
Database (S:\SG3DB)	0.103	0.032	402.301	7.087	(n/a)
Database (S:\SG4DB)	0.074	0.022	407.920	7.466	(n/a)
Log (S:\SG1LG)	0.001	0.001	57.225	2.161	3600.866
Log (S:\SG2LG)	0.001	0.001	59.414	2.283	4003.164
Log (T:\SG3LG)	0.001	0.001	57.926	2.073	3801.690
Log (T:\SG4LG)	0.001	0.001	59.781	2.297	4497.935

Host system performance

Counter	Average	Minimum	Maximum
% Processor Time	5.243	2.148	12.012
Available MBytes	14866.729	14678.000	15724.000
Free System Page Table Entries	16758131.000	16758131.000	16758131.000
Transition Pages RePurposed/sec	0.000	0.000	0.000
Pool Nonpaged Bytes	61300053.333	61038592.000	62406656.000
Pool Paged Bytes	46403896.889	46170112.000	46739456.000
Database Page Fault Stalls/sec	0.000	0.000	0.000

Test Log

10/11/2007 7:53:32 PM -- Command Line:

"C:\PROGRA~1\EXCHAN~1\jetstresscmd.exe" /c "C:\Q4\Jetstress\4SG\1t\soft\soft.xml"

10/11/2007 7:53:32 PM -- Jetstress testing begins ...

10/11/2007 7:53:32 PM -- Prepare testing begins ...

10/11/2007 7:53:37 PM -- Attaching databases ...

10/11/2007 7:53:37 PM -- Prepare testing ends.
 10/11/2007 7:53:37 PM -- Dispatching transactions begins ...
 10/11/2007 7:53:37 PM -- Database cache settings: (minimum: 128.0 MB, maximum: 1.0 GB)
 10/11/2007 7:53:37 PM -- Database flush thresholds: (start: 10.2 MB, stop: 20.5 MB)
 10/11/2007 7:53:42 PM -- Database read latency thresholds: (average: 0.02 seconds/read, maximum: 0.05 seconds/read).
 10/11/2007 7:53:42 PM -- Log write latency thresholds: (average: 0.01 seconds/write, maximum: 0.05 seconds/write).
 10/11/2007 7:53:43 PM -- Operation mix: Sessions 1, Inserts 25%, Deletes 10%, Replaces 50%, Reads 15%, Lazy Commits 80%.
 10/11/2007 7:53:43 PM -- Performance logging begins (interval: 15000 ms).
 10/11/2007 7:53:43 PM -- Generating log files ...
 10/11/2007 8:57:46 PM -- S:\SG1LG (100.2% generated), S:\SG2LG (103.2% generated), T:\SG3LG (100.8% generated), and T:\SG4LG (103.8% generated)
 10/11/2007 8:57:47 PM -- Performance logging ends.
 10/11/2007 8:57:47 PM -- JetInterop batch transaction stats: 9830, 9973, 9934, and 9846.
 10/11/2007 8:57:48 PM -- Dispatching transactions ends.
 10/11/2007 8:57:48 PM -- Shutting down databases ...
 10/11/2007 8:57:50 PM -- Instance1620.1 (complete), Instance1620.2 (complete), Instance1620.3 (complete), and Instance1620.4 (complete)
 10/11/2007 8:57:50 PM -- C:\Q4\Jetstress\4SG\1t\soft\Performance_2007_10_11_19_53_42.blg has 256 samples.
 10/11/2007 8:57:50 PM -- Creating test report ...
 10/11/2007 8:57:51 PM -- Volume T:\SG1DB has 0.0081 for Avg. Disk sec/Read.
 10/11/2007 8:57:51 PM -- Volume T:\SG2DB has 0.0078 for Avg. Disk sec/Read.
 10/11/2007 8:57:51 PM -- Volume S:\SG3DB has 0.0089 for Avg. Disk sec/Read.
 10/11/2007 8:57:51 PM -- Volume S:\SG4DB has 0.0076 for Avg. Disk sec/Read.
 10/11/2007 8:57:51 PM -- Volume S:\SG1LG has 0.0008 for Avg. Disk sec/Write.
 10/11/2007 8:57:51 PM -- Volume S:\SG1LG has 0.0008 for Avg. Disk sec/Read.
 10/11/2007 8:57:51 PM -- Volume S:\SG2LG has 0.0009 for Avg. Disk sec/Write.
 10/11/2007 8:57:51 PM -- Volume S:\SG2LG has 0.0006 for Avg. Disk sec/Read.
 10/11/2007 8:57:51 PM -- Volume T:\SG3LG has 0.0009 for Avg. Disk sec/Write.
 10/11/2007 8:57:51 PM -- Volume T:\SG3LG has 0.0009 for Avg. Disk sec/Read.
 10/11/2007 8:57:51 PM -- Volume T:\SG4LG has 0.0009 for Avg. Disk sec/Write.
 10/11/2007 8:57:51 PM -- Volume T:\SG4LG has 0.0010 for Avg. Disk sec/Read.
 10/11/2007 8:57:51 PM -- Test has 0 Maximum Database Page Fault Stalls/sec.
 10/11/2007 8:57:51 PM -- Test has 0 Database Page Fault Stalls/sec samples higher than 0.
 10/11/2007 8:57:51 PM -- C:\Q4\Jetstress\4SG\1t\soft\Performance_2007_10_11_19_53_42.xml has 255 samples queried.
 10/11/2007 8:57:51 PM -- C:\Q4\Jetstress\4SG\1t\soft\Performance_2007_10_11_19_53_42.html is saved.
 10/11/2007 8:57:52 PM -- Performance logging begins (interval: 2000 ms).
 10/11/2007 8:57:52 PM -- Recovering databases ...
 10/11/2007 9:02:42 PM -- Performance logging ends.
 10/11/2007 9:02:42 PM -- Instance1620.1 (282.5), Instance1620.2 (278.25), Instance1620.3 (288.5), and Instance1620.4 (274.5)
 10/11/2007 9:02:42 PM -- C:\Q4\Jetstress\4SG\1t\soft\SoftRecovery_2007_10_11_20_57_51.blg has 144 samples.
 10/11/2007 9:02:42 PM -- Creating test report ...

Microsoft Exchange Server Jetstress streaming backup test results

Streaming backup test result report

Streaming backup statistics - All

Database Instance	Database Size (MBytes)	Elapsed Backup Time	MBytes Transferred/sec
Instance2604.1	98300.77	02:37:49	10.38
Instance2604.2	98300.77	02:32:53	10.72
Instance2604.3	98300.77	02:34:02	10.64
Instance2604.4	98300.77	02:38:29	10.34

Jetstress system parameters

Thread count	1 (per-storage group)
Log buffers	9000
Minimum database cache	128.0 MB
Maximum database cache	1024.0 MB
Insert operations	25%
Delete operations	10%
Replace operations	50%
Read operations	15%
Lazy commits	80%

Disk subsystem performance

Database Instances	Database Reads Latency	Database Writes Latency	Database Reads/sec	Database Writes/sec	Log Reads Latency	Log Writes Latency	Log Reads/sec	Log Writes /sec	Log Writes Bytes
Instance2604.1	6.902	0.114	83.629	0.000	0.000	0.000	0.000	0.000	0.000
Instance2604.2	6.412	0.000	86.302	0.000	0.000	0.000	0.000	0.000	0.000
Instance2604.3	6.325	0.012	85.670	0.000	0.000	0.000	0.000	0.000	0.000
Instance2604.4	6.859	0.000	83.153	0.000	0.000	0.000	0.000	0.000	0.000

Host system performance

Counter	Average	Minimum	Maximum
% Processor Time	31.888	14.297	56.452
Available MB	15256.769	14976.000	15780.000
Free System Page Table Entries	16758298.067	16758271.000	16758431.000
Transition Pages RePurposed/second	10289.233	0.000	23667.301
Pool Nonpaged Bytes	71932993.641	57696256.000	78999552.000
Pool Paged Bytes	571517538.462	44216320.000	846614528.000
Database Page Fault Stalls/second	0.000	0.000	0.000

Test Log

10/12/2007 3:08:37 PM -- Command Line: "C:\PROGRA~1\EXCHAN~1\jetstresscmd.exe" /c "C:\Q4\Jetstress\4SG\1t\b2d\b2d.xml"

10/12/2007 3:08:37 PM -- Jetstress testing begins ...

10/12/2007 3:08:37 PM -- Prepare testing begins ...

10/12/2007 3:08:42 PM -- Attaching databases ...

10/12/2007 3:08:42 PM -- Prepare testing ends.

10/12/2007 3:08:47 PM -- Performance logging begins (interval: 15000 ms).

10/12/2007 3:08:47 PM -- Streaming backup databases ...

10/12/2007 5:47:18 PM -- Performance logging ends.

10/12/2007 5:47:18 PM -- Instance2604.1 (100% processed), Instance2604.2 (100% processed), Instance2604.3 (100% processed), and Instance2604.4 (100% processed)

10/12/2007 5:47:18 PM -- [C:\Q4\Jetstress\4SG\1t\b2d\StreamingBackup_2007_10_12_15_8_42.blg](#) has 624 samples.

10/12/2007 5:47:18 PM -- Creating test report ...